

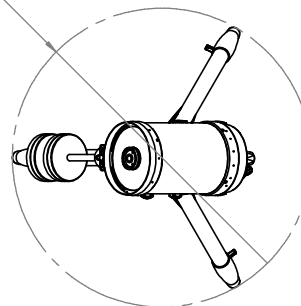

**Note:**

1. This drawing represents the telescope system setup at 40° latitude.
2. Overall height and footprint of the telescope system will vary by the setup processes, latitude and environment.
3. This assembly drawing represents both CGX 8" SCT and 8" EdgeHD telescopes.

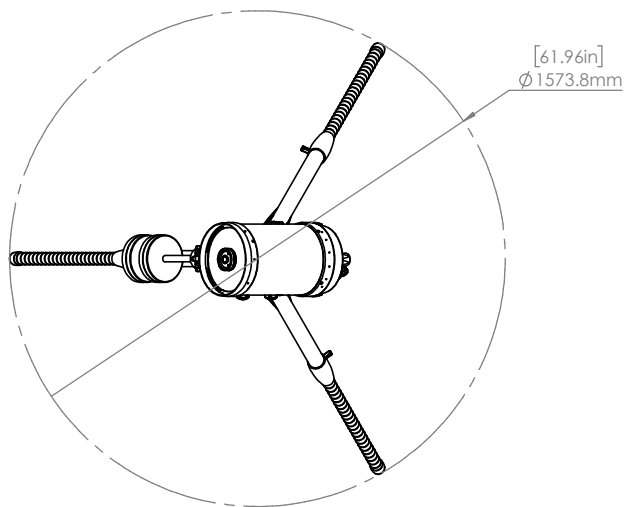
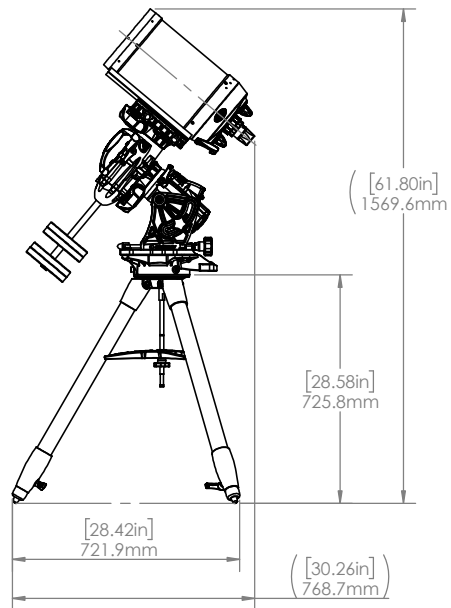
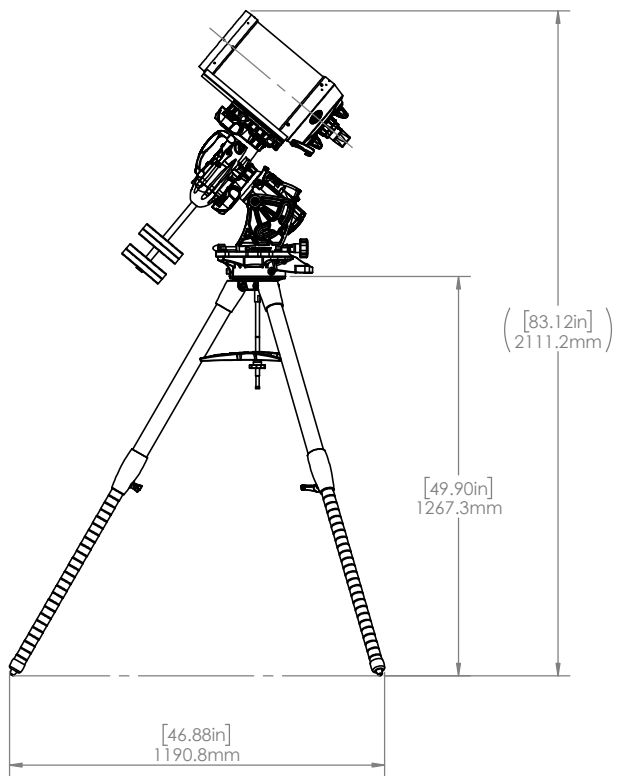

UNLESS OTHERWISE SPECIFIED:		NAME	DATE	 2835 Columbia St. Torrance, CA 90503
DIMENSIONS ARE IN MILLIMETER		DRAWN	WM	
TOLERANCES:		CHECKED		<b>TITLE:</b> CGX 8" EdgeHD Full Setup
FRACTIONAL: ±		ENG APPR.		
ANGULAR: MACH: ±0.50		MFG APPR.		
TWO PLACE DECIMAL: ±0.20		Q.A.		
THREE PLACE DECIMAL: ±0.005		COMMENTS:		SIZE DWG. NO. REV <b>C</b> CGX 8 HD X2
INTERPRET GEOMETRIC TOLERANCING PER:				SCALE: 1:20 WEIGHT: SHEET 1 OF 1
MATERIAL:				
FINISH:				
DO NOT SCALE DRAWING				

**PROPRIETARY AND CONFIDENTIAL**  
 THE INFORMATION CONTAINED IN THIS DRAWING IS THE SOLE PROPERTY OF CELESTRON, LLC. ANY REPRODUCTION IN PART OR AS A WHOLE WITHOUT THE WRITTEN PERMISSION OF CELESTRON, LLC IS PROHIBITED.